

- Designed for handling thin plastic and paper bags
- Ultra thin seal lip ensures vacuum tight seal
- Ideal for bag opening and transfer
- High flow cup fitting
- Available in FDA silicone as standard



SBLP		30		S		G1/4	
Series	Model	Diameter	Cup Material		Fitting Thread		
	30	30	S	Red Silicone	G1/4	G1/4	
	40	40	SMI	Metal Impregnated Red Silicone	N1/4	1/4NPT	
	50	50	STMI	Metal Impregnated White Translucent Silicone	G3/8	3/8NPT	
					N3/8	3/8NPT	
					G1/2	G1/2	
					N1/2	1/2NPT	

Part number example SBLP40S
 40mm vacuum suction cup in silicone
 Part number example SBLP40S-G3/8
 40mm vacuum suction cup in silicone with male G3/8 Cup Fitting

CUP DIMENSIONS (mm)

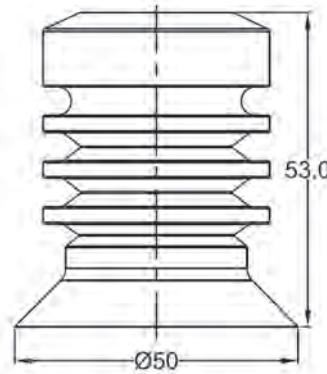
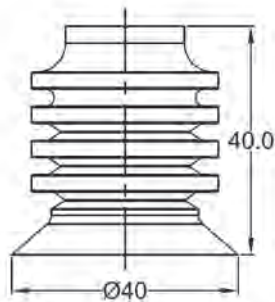
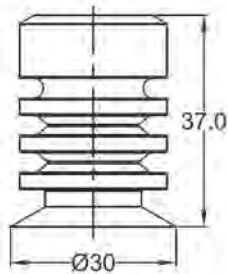

This cup series is available in metal detectable FDA compliant silicone. For red colored metal detectable silicone use material code SMI. For white translucent metal detectable silicone use material code STMI.

CUP + FITTING DIMENSIONS (mm)

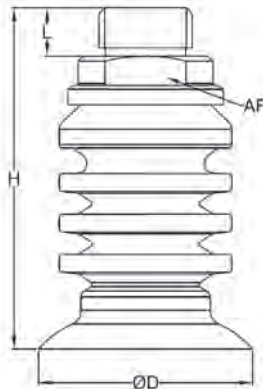

Fitting Model	Cup ØD	H	L	AF
SBLP-G1/4	30	51.5	9	19
SBLP-N1/4	30	51.5	11.5	
SBLP-G3/8	40	56	10	22
SBLP-N3/8	40	57.5	11.5	
SBLP-G1/2	50	69	10	28
SBLP-N1/2	50	69	16	

SBLP Vacuum cup fittings are designed to ensure maximum flow is applied to the cup sealing lip to ensure maximum grip.

